

7611D2-L/7611D2-S Series Bright★Pipes™ Optical Lightpipes
DESCRIPTION AND FEATURES

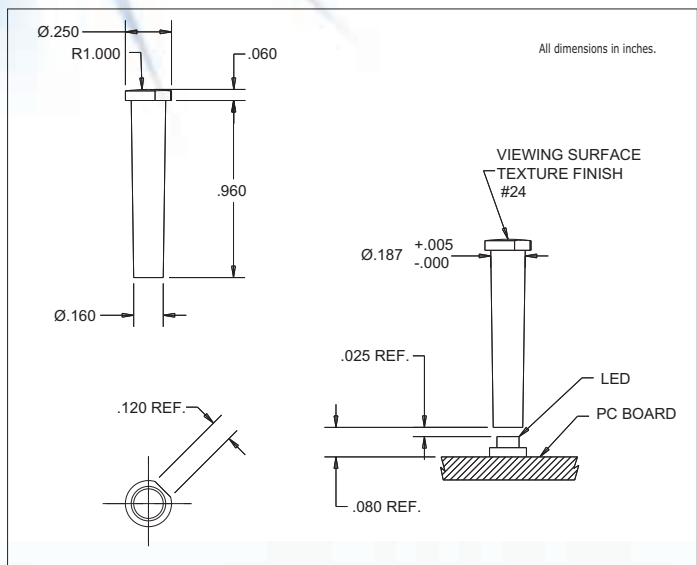

7611D2-L

- Precision engineered with **ray tracing** for bright, optically precise even indication and attractive appearance.
- ESD protection from circuitry for exceptional reliability.
- High contrast and wide viewing angle for greater visibility.
- Available in a variety of colors for added contrast and aesthetics.
- Panel mounting.
- Both 7611D2-L and -S light pipes are designed for use with 7016X series Bright Chip LEDs.

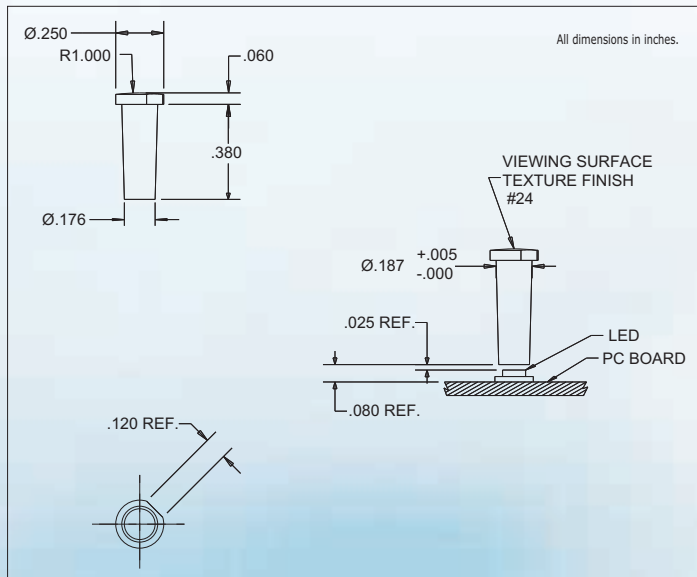

7611D2-S